



When used, library buildings show up, take profit of it!

Mercè Millán

E-mail: millantm[at]diba.cat

Ester Omella

E-mail: omellace[at]diba.cat

Assun Viladrich

E-mail: viladrichna[at]diba.cat

Gerència de Serveis de Biblioteques
Diputació de Barcelona
Barcelona, Spain

Session:

190 — Making the case for change through evaluation: post-occupancy evaluation of library buildings — Library Buildings and Equipment

Abstract:

Barcelona is one of the 4 provinces in Catalunya, an autonomous region of Spain. In the province of Barcelona there is a population of more than 5.4 million inhabitants, distributed in 311 cities and towns.

The Diputació de Barcelona is an institution of a supra-municipal whose goal is helping towns of the province to offer municipal services to the citizens.

*Library Services Management of the Diputació de Barcelona (LSM) gives advice and support to local authorities in the process of library service creation and development, leading the Municipal Libraries Network in the province of Barcelona. The Public Libraries Network of the province of Barcelona is made up, as of December 2011, of **208** libraries and **9** book mobiles that provide direct service to people of **237** municipalities (representing 97.5% of the province's total population). At the end of 2011 the Network had **2.3** million registered library card holders (that is 42% of the total population). In the course of the same year, the Network reached **18.9** million accumulated visits and **13** million loans.*

The aim of the Library Services Management is to enable the province's municipalities to take on the creation and maintenance of their libraries in an efficient way, on the basis of networking. One of the fundamental Areas of work around which the LSM organizes its services is the planning, creation and improvement of libraries.

*During the years 2010 and 2011 was performed in **33** equipments in the province of Barcelona: **17** newly created, **7** moved and **9** expanded.*

Our communication wants to present the process and post-occupancy evaluation results of 11 library buildings opened during this period.

The evaluation is based on a questionnaire developed as a result of a working process with the participation of all the professionals involved in the process of creation and improvement of Public Libraries: Planning, Architecture Library, Technology and Telecommunications, the Library Directors and the responsible for culture in the municipalities.

It will develop:

- The importance of including evaluation in the post-opening process of creation and improvement of a library.*
- Questionnaire used and priority areas of study. Areas incorporated in 2010. The questionnaire is showed, among other things:*
 - space organization*
 - desk location*
 - lighting*
 - air conditioning and noise*
 - furniture in relation with the equipment*
 - technology telecommunications and audiovisual media*
 - organization's collection*
 - organization of the building to facilitate the library use and the work of staff*
- Diagnosis, assessment inputs in different fields of study. Major issues include improvement in libraries. A diagnosis of the 11 libraries with 4 case studies (drawings and photos) will be showed.*
- Immediate consequences include the evaluation stage in the process. Main elements of cause and effect. We develop the actions take in this process to improve the library itself and also for the other libraries in the network.*
- Conclusions*

We will emphasize the outcome of the process. The implementation of the evaluation process has led to many changes in the organization and has highlighted the need to implement improvements that respond to the library model and spaces, more oriented to users: library better equipped, as well as the efficiency in the use of energy, as well as the importance to take into account the maintenance expenses when designing a new library.

TABLE OF CONTENTS

1 Introduction	3
2 Post-inauguration evaluation stage in the whole of the process of creation and improvement of a library.....	4
3 Questionnaire used and priority fields of the study	7
4 Diagnosis of the evaluation – input on different fields of study. Principal aspects of improvement to add on libraries.....	13
5 Immediate consequences of including the evaluation stage in the process of creation and improvement of a library	19
6 Conclusions.....	24
7 Annexes.....	25

1 Introduction

Barcelona is one of the 4 provinces in Catalonia, an autonomous region in Spain. The province of Barcelona has a population of more than 5.4 million inhabitants, distributed in 311 cities and towns. The Diputació de Barcelona is a supra-municipal institution whose goal is helping the province towns to offer municipal services to the citizens.

Public libraries in Barcelona are a shared project between City Councils, which have its competence, and the Diputació de Barcelona, which provides help and services, favours cooperation and facilitates networking.

The Public Libraries Network of the province of Barcelona (XBM) is made up, as of December 2011, of 208 libraries and 9 book mobiles that provide direct service to people of 237 municipalities (representing 97.5% of the province's total population). At the end of 2011 the Network had 2.3 million registered library card holders (that is 42% of the total population). In the course of the same year, the Network reached 18.9 million accumulated visits and 13 million loans.

During the years 2010 and 2011 building works were performed in 33 premises in the province of Barcelona: 17 newly created, 7 moved and 9 expanded.

Collaboration and complicity between the City Councils and the Diputació de Barcelona was essential for the development of the libraries in the province in the last 25 years. It is important to emphasise that the support of the Diputació for the libraries and networking has a historical tradition that goes back to the beginning of the 20th century. At present libraries have an important social acknowledgement and it is the public service better valued by citizens in municipal surveys across many City Councils.

Equity of access and use of the libraries, economic sustainability, efficiency, quality of the service and membership are the five dimensions that make possible the evolution of the model of management and provision of service of public libraries in the province of Barcelona. The economic sustainability that

this model of management and provision of service brings has been a key aspect for the City Councils and it is so at present, bearing in mind that local properties' weakness is even more critical, if possible, in the present economic context, and especially if we consider that 40% of their income comes from transfers from other administrations (and so they are not controlled directly). Considering these circumstances, providing a quality library service would be very difficult to take on only by City Councils, and it is because of this that the role of the Diputació de Barcelona is essential.

On the other hand, committing to this management model has allowed libraries to evolve and to improve their services at a pace set by social changes and to reflect the profile of citizenry that they serve, becoming genuine spaces of social cohesion, as well as cultural and educative.

The mission of the Gerència de Serveis de Biblioteques (Management of Library Services, from hereon on MLS) is:

"The Gerència de Serveis de Biblioteques of the Diputació de Barcelona assesses and gives services and support to City Councils in creation and provision of quality library services, and leads the Xarxa de Biblioteques Municipals of the province of Barcelona, promoting optimisation of existing resources, of economies of scale and networking, in order to guarantee territorial balance and equity of access for the whole citizenry to information, knowledge and culture¹.

Networking in the province of Barcelona allows to achieve three key aspects:

- Production of services in economies of scale
- Cooperative working of libraries, and
- Access for the citizens to the whole of the library resources, in terms of equity.

2 Post-inauguration evaluation stage in the whole of the process of creation and improvement of a library

2.1 Objectives of the evaluation

Library architecture has to evolve at the pace of the library and, at the same time, has to foresee its evolution, anticipating the architectural necessities that this evolution would need.

¹ Mission that appears in Pla Estratègic 2012-2015

It is comprehensible² that professionals and institutions involved in the creation and improvement of a library should look forward to the opening of the service. In spite of this, no one doubts that it is important to evaluate and document the whole progress and the results.

It is particularly important that an institution like ours should consider evaluation, because we boost and participate in various projects of new premises, and in this context it is necessary that the new projects should nourish from improvement opportunities detected in existing libraries, in a process that should be considered of a continuous improvement.

From the MLS we boost this subsequent evaluation considering aspects related both to the improvement of the process and to the final result. Amongst these, the principal elements to value are: coordination between administrations involved in the provision of service, the relationship architects-librarians, timing and the deadlines performance and solution of possible unforeseen events. In the evaluation of the final result, elements such as architecture of the building, the distribution of areas, the collection, the equipment and the furniture are evaluated. All of this with the purpose of:

- Improving provisions for the users of library services
- Improving conditions of the staff's working place, especially the customer service and the lending service
- Planning more sustainable buildings, both environmentally and economically

As we said in the previous section, the MLS assesses and collaborates with the City Councils in planning, creating and improving library premises. Evaluation is a key stage, linked with the other stages that define the process of creation and improvement of a library:

- Previous analysis
- Service programming
- Architectural project
- Building work execution
- Furniture and equipment
- Planning of the new service management
- Service opening
- Evaluation and documentation of the whole process

² For the difficulty of the processes, among other reasons.

Below we show the diagram of processes and the principal purposes of the MLS in each stage. In section 4 of this presentation, the specific purposes of the post-inauguration evaluation stage for library buildings are developed.

2.2 Diagram of processes of creation and improvement of a library

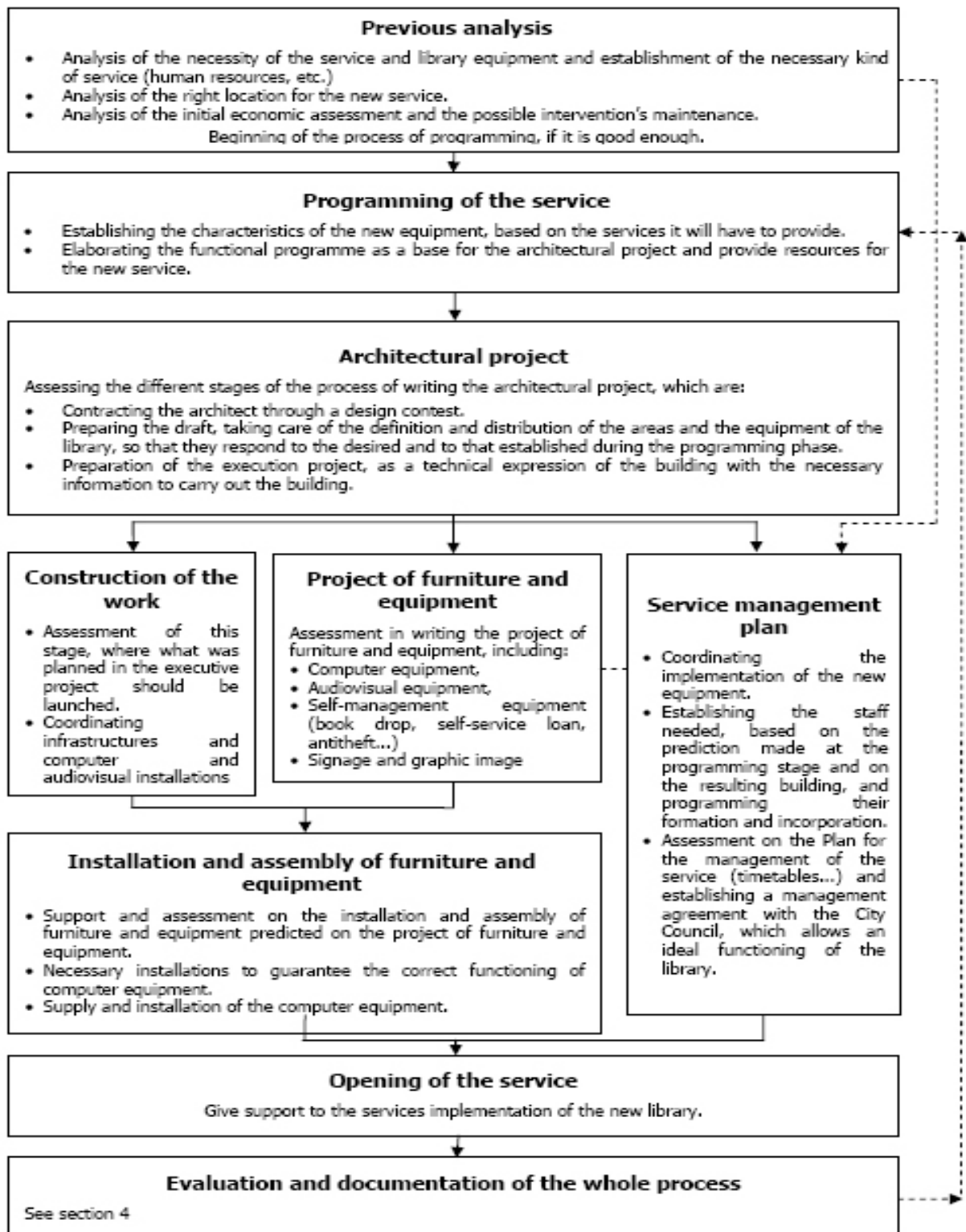

3 Questionnaire used and priority fields of the study

The three basic criteria to create and improve a library are: accessibility, flexibility and organisation. Starting from this premise, the success of a new library building needs a good distribution of the areas and the services that facilitate interaction between users and documental collections.

Wanting to improve processes and tasks that are carried out to unveil or improve a library, brought us to thinking of elaborating some evaluation documents aimed at the directors of the libraries, to gather their opinions before, during and after the whole process of assembly, unveiling and subsequent functioning of the libraries. These questionnaires had to be analysed and valued. And finally some conclusions had to be reached. These conclusions were useful to reconsider and improve from building themes and organisation of spaces to a collection, services, work load or furniture organisation.

We considered carrying out an evaluation through some questionnaires that would be both lively to answer by the teams that manage libraries and that would respond to the three areas that we wanted to highlight.

3.1 Questionnaires and study areas

Below we will explain in detail the questionnaires that we developed in three different areas:

- 1st: Tasks at the Unitat de Programes i Equipaments (Programmes and Equipments Unit; from now on, UPE) and assembling at the library.
- 2nd: Secció de programació Territorial i Equipament (Section of Territorial and Equipment programming; from now on, SPTE) – Monitoring file
- 3rd: Unitat d'Arquitectura Bibliotecària (Library Architecture Unit; from now on UAB) – Monitoring file

This order only responds to the fact that the initiative came from the UPE and that we wanted to evaluate basically the tasks that were carried out from this Unit, which are mainly aimed to the assessment of staff, to the management of equipment, formation, collection... (see annex 1a)

Subsequently we detected the need to include other topics that are worked on from the Section, such as concepts relating to the library architecture and other premises that belong to the interior of the building: location and functionality of

the furniture, location of screens, self-listening equipment and viewing equipment, acoustic comfort, lighting... (see annex 1b)

Finally we included a questionnaire that responds to logistics and computing, by request of workers from other Units or Services of the MLS with whom we work together launch the new library (see annex 1c)

3.2 Methodology

The procedure is to send these questionnaires about the different processes carried out to the directors of the new libraries or those libraries which have been expanded and improved, to wait for the answers and afterwards carry out an individualised synthesis for each library, and to also do this at a global level. The first one shows us what the already-running library is lacking and therefore must be improved, and the second one makes us think about the things we have to change and are able to improve when programming future premises.

The structure of the three questionnaires is the same, but the appraisal that the library staff makes varies between the first two and the third:

- In the two first cases, each task carried out at and by the UPE is appraised, as well as the aspects regarding library architecture, sound and image equipment, signage, with a table that goes from 1 (very bad) to 5 (very good).
- In the case of the building and equipment, we base the appraisal on knowing if the aspects of logistics and computing are working when starting the assembly of the premise, on the day of the inauguration and two months after it, asking for a yes/no answer.

All in all we make an evaluation about the building, its equipment, the collections and the services we provide: existences, absences and grade of satisfaction.

3.3 Feed-back of the libraries

This is the collection of data received by the libraries that have answered the questionnaires. We present a synthesis that collects the average appraisal and we comment on which parts are most meaningful of what the directors of the 5 evaluated libraries have sent us.

We will follow the same order of the questionnaires presented on section 3.1:

1st: Tasks at the UPE and assembling at the library:

Staff	Appraisal
Welcome and tasks on the unit	4.4
Millennium training	4
Management hours	4.1
Comments:	
<ul style="list-style-type: none">▪ Favourable reception▪ Lot of theory and not so much practice. Lack of time.	
Support to management	Appraisal
Arrangement of the collection	4.2
Distribution of work load	3.9
Planning of library hours	4.4
Signage	3.6
Collection	Appraisal
Expurgation	4.4
Logistics	4.4
Timing	3.5
Organisation at UPE	3.7
Treatment at UPE	4.1
Assembly at the library	3.8
Incidents on the collection	4
Subscription	4.2
Comments:	
<ul style="list-style-type: none">▪ The necessary expurgation was not possible to carry out▪ It would have been good to work with the collection itself▪ Too fast assembly▪ Contents of signage were decided with little time▪ Not enough time	

Library architecture	Appraisal
Location of the counters	4.4
Dimensions of the counters	3.6
Furniture: functionality	3.7
Arrangement of the furniture	4
Natural light	4
Artificial light	4
Heating and air conditioning	3.4
Acoustic comfort	3.3
Quantity of public use sockets	3.9

Comments:

- Very separated desks because of the space, but well located strategically.
- Adults' desk with a shape that makes going through with carts difficult.
- Not functional enough desks
- At the children's area leaning shelves and music furniture were missing.
- There are areas where there is light dazzle.
- Noise comes from the lower floor
- There is noise on the stairs
- Public use sockets missing

Programmes and equipments	Appraisal
Information screen	2.7
CD for own use	3.4
DVD for own use	3.5
TV	3.6
Labelling	3.6

Comments:

- Some TVs are too small
- Screens for DVD for own use are too large and not very operative
- Wireless headphones that do not receive TV signal but do receive radio frequencies.

<u>Logistics</u>	<u>Beginning</u>	<u>Opening</u>	<u>Present</u>
Water	yes	yes	yes
Alarms	yes	yes	yes
Antitheft	yes	yes	yes
Lift	no	no	yes
Toilets	no	yes	yes
Light	yes	yes	yes
Complete furniture	yes	yes	yes
Cleaning	no	yes	yes
Telephone	yes	yes	yes
<u>Computing</u>	<u>Beginning</u>	<u>Opening</u>	<u>Present</u>
Computing wiring	yes	yes	yes
Stabilizer	yes	yes	yes
Municipal ADSL Line	yes	yes	yes
Diba ADSL Line	yes	yes	yes
Management PCs	no	yes	yes
Wi-Fi	no	yes	yes
Internet and more	no	yes	yes
Catalogues	no	yes	yes
Printers	no	yes	yes
Comments:			
<ul style="list-style-type: none"> ▪ Cleaning at the beginning was not daily (2 libraries) ▪ The building itself represents greatly the library management work. ▪ There are computers that were not installed because of the lack of sockets. 			

3.4 Conclusions

After analysing the evaluation carried out by the directors of the libraries we can draw some conclusions that will allow us to tackle an improvement plan which will affect mainly aspects that have received an average punctuation of less than 4.

Staff section (Tasks at UPE):

Formation and practice: it is necessary to try to carry out a previous formation to Millennium which covers everything that a person who starts from scratch in a library needs to know. To promote the practical aspect of the formation, both for the Millennium software and for the functioning of the library.

Support to the manager section (tasks at UPE):

Reconsideration of the support to the manager. See where it is necessary to stress and what we can offer from scratch.

Collection section (tasks at UPE):

Improve the timing calendar for buying and treating the collection. Define reading interest arrangements, consolidated so we can select them during assembly and exhibit them easily.

Library architecture section (Secció de Programació Territorial i Equipament):

The importance of the premise architecture, as well as the furniture, for the ideal functioning of the service can be noticed from the various comments on the surveys. The most recurrent topics are: tables, dazzling and bad acoustics.

Programmes and equipments section (Secció de Programació Territorial i Equipament):

Regarding audiovisual elements, the size and the features of the equipment should be redefined and the installation company should provide some formation for the staff on the use of this equipment.

Logistics section (Edifici i equipament):

We detect cases in which aspects as important as cleaning the building and the toilets are not planned when doing the transfer and starting the assembly.

Computing section (Edifici i equipament):

Installation and configuration of informatics equipment are intimately linked with logistics, since if tables and cables are not assembled or the lighting is not on, computer specialists cannot work on the equipment.

4 Diagnosis of the evaluation – input on different fields of study. Principal aspects of improvement to add on libraries

Why do we evaluate?

To improve and develop as a public service which provides cultural offers for our citizens. We have focused on improvement fields in library services, in library staff and the maintenance of the equipment in the economic and management field.

4.1 Improving provisions for the users of library services

How?

4.1.1 Reader interest arrangements

For some time now, public libraries both from Europe and from America have been thinking that the traditional organisation of the documental collection following the Dewey classification does not adapt to demands from the public. It is because of this concern that new presentation ways for the documental collection at libraries were developed, following the interests from the users: reader interest arrangements where documentation is analysed and organised following the interests of the reader.

Catalan libraries have developed reader interest arrangements³ that are very successful, and it has brought us to rethink and evaluate the organisation of the documental collection. This organisation has a direct repercussion both on organisation and on the approach of the uses, the type of shelving, furniture, signage and areas of the library.

Rising from these libraries which are interested in the creation of reader interest arrangements, the MLS has decided to evaluate the organisation of the collection. We have to bear in mind that documents which with the CDU classification would be dispersed around the library, are put together in a specific area, so users won't have to look around all the shelves to find what they are looking for in the whole of the documental collection. An example of what we are talking about is the reader interest arrangement of "parent's area",

³ The most used in XBM libraries are the following:

Self-learning languages, self-help, self-learning, comic books, personal growing, cooking, decoration, traditional celebrations, tourism and travelling guides, easy-reading, world of work/competitive examination, multiculturalism, born to read and parent's area.

placed in the children's area and where books thought for adults about various topics can be found (pregnancy books, children's psychology, nutrition, learning, games, travelling with infants...)

It is necessary to remember that reader interest arrangements coexist with the traditional organisation ways.

What has this analysis provided?

1st. To determine that from the MLS we have to present a project of reader interest arrangements to make libraries more dynamic and flexible.

2nd. To consider: needs of space and furniture

- Specific areas to present these reader interest arrangements. Areas that are very visible from the different reading areas. Display areas where the user can identify them easily.
- Specific, informal furniture (shelving, armchairs or cushions).
- Signage that shows the users where they are in the area and in the documental collection.

4.1.2 Young areas (14-25 years)

For some years now we have detected that young people from 13 to 22 years old do not use the library. The library, which was until these ages, a meeting point with reading, knowledge, technologies and friends becomes premises that do not give them anything.

Both the library directors and the City Councils demand from us an area designed for young people. In Catalan libraries we already have areas of different characteristics according to different user types: area for the small readers, comic book area, children's area, music and magazines area, general area, workshops area, tales area...

Library directors tell us that young people become diluted in the space for adults and do not have their own space or a documental collection appropriate for their interests.

On the contrary, we know that the library is one of the most valued premises in the survey for the "Plans Locals de Joventut" (local plans for young people). This makes us consider that we must not lose the chance of making the most of this good appraisal. And act accordingly to make a design of uses and areas.

We presented a proposal that we know now, thanks to the evaluations carried out, did not have the desired result.

We presented a meeting area for young people, which did not fulfil what we wanted; they were transformed into study areas and not places to meet with reading, information and/or culture.

What has this analysis provided?

1st. That the topics for young people become a special important element in the development of policies for young people of the municipalities, and that library directors see the need for presenting a service and an offer to promote reading for these ages.

2nd. To consider: needs of space and furniture.

- To build an area of proximity for young people's interests and needs, so they gain a meeting point. Now we know that these areas have to be, in the majority of cases, the axis for policies of young people at a local level.
- A single formula or a single model of premise for all the municipalities does not exist. We have to start from the reality of each municipality to adapt the areas to their reality and their needs, and to the kinds of services that they want to provide to be able to consolidate the autonomy process of the young person.
- We have to copy and improve the existing meeting points with:
 - Multipurpose areas with little furniture, to facilitate flexibility.
 - Enclosed spaces with a provocative design thinking about young people's taste, considering the tendencies of the moment.
 - Technology areas with Wi-Fi, TV, video games equipment
 - Specific, informal furniture (shelving, armchairs or cushions...)
 - Signage that leads the users to where they are in the area and in the documental collection.
 - Display areas where both documents and pieces of work carried out by users can be exhibited.

4.1.3 Reference areas

The evolution of the virtual reference and the increase of Internet use among the citizens have drastically reduced the use of these areas. This is confirmed by the libraries, although we are warned that there is a profile of person (usually not used to using internet) that use the printed versions of encyclopaedias, dictionaries, atlas, yearbooks and other materials. On the other

hand, from the central services we have more difficulties to acquire documents of this kind, because the editorial supply is becoming limited.

Until not long ago, reference areas had a main role in the distribution of areas and were located in very visible places, set out from the rest of the documental collection. Considering changes in the use dynamics of the reference works (online access is better than printed access) and of the editorial market evolution, from the MLS we have started to organise this documental typology in a more integrated way to the rest of the library collection. In the libraries opened during these last years, different formulas of organisation have been tried; after some time of functioning these were valued in order to introduce improvements on the organisation of new libraries.

What has this analysis provided?

1st. Realise that there cannot be a single organisation system: that depending on the library type and the characteristics of the potential public of its influence area, a more differenced or integrated organisation system has to be considered.

2nd. Although they are not frequently used, reference works still have users and cannot disappear from the library. To promote their use we make it possible to borrow them (until not long ago, the majority of reference works were excluded from lending)

3rd. To elaborate, from the MLS, some performance guidelines about organisation and contents of the reference areas, aimed at existing libraries to adapt them to present tendencies.

4th. To rethink organisation and exhibition of the library collection in a global way, the reference works aside. In existing libraries, the gaps that reference areas have left, have been occupied by novelty displays and reading interest arrangements, following an organisation and presentation of the collection models which is much more attractive for the user.

4.2 Improving conditions of the staff's working place, especially the customer service and the lending service

How?

With newly designed furniture to avoid working risks, such as the lending desk.

4.2.1 Lending desk

It is an important architectural element in the image of the library; it is the first piece of furniture that can be seen when entering the premises. And not only

visually but also because it is a working space where the whole process of borrowing and returning the library documents takes place. Moreover, it is the principal centre of the library.

The desk is the object of a lot of criticism, at the same time from users, from staff and from the architects of the project.

New present features, the lack of staff and the strong work load from the staff. We have met the need to improve features of this piece of furniture.

What has this analysis provided?

1st. To be conscious of the complexity of the subject. This is why it is so complicated to reach a solution: because of the influence of many aspects and points of view.

2nd. To consider: needs of space and furniture

- Gauging the proportions that help diminish efforts from the staff.
- Making work for left- and right-handed people easier.
- Facilitating the worker's movement along the desk with their working chair without their legs getting in the way.
- Disabled people with wheelchairs (library staff and/or users)
- Avoiding messiness.
- Interior intimacy (not feeling invaded) and how the user approaches the desk.
- Ensure a visual relationship with the users.
- Materials have to be comfortable and secure.

For some time now we have been working to improve. Changes have been incorporated according to the needs and, in some cases, solutions to determined problems have been found.

There are some related regulations, but they are not very clear. Now, starting from various collected aspects and with the purpose of ensuring relation between design, functionality and an adequate dimension, certain measurements are being worked on, bearing in mind the previous concepts and others such as: the worker can be standing up or sitting down, the chair must adjustable and the desk is enclosed so the legs cannot be seen. A space has been incorporated so the user can use it to rest books on it and the staff's effort to take these books is reduced.

This new proposal is believed to bring aesthetic problems.

It should be borne in mind that with new technologies and the possibility of incorporating RFID technology, some changes will make the user more autonomous; this will produce changes on the desk as well.

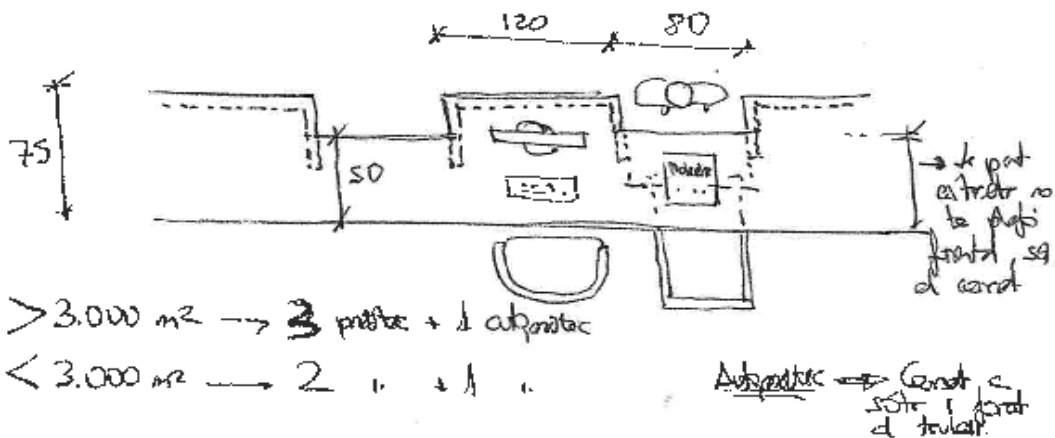
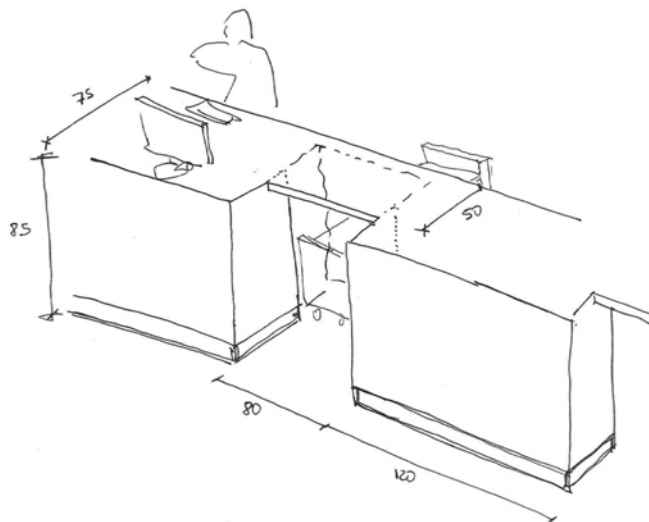

4.3 Planning more sustainable buildings, both environmentally and economically

How?

4.3.1 With usage organisation

It has been long since we have detected that in our public libraries more than one duty is carried out, not only promoting reading, but also promoting information, formation of social centres, human relations, social cohesion...

nowadays libraries are so greatly used that a strong need for maintenance of the building and the furniture appears.

What has this analysis brought us?

1st. To value how we can reduce costs without losing quality of materials, and to facilitate maintenance of the buildings from a better organisation of the services provided by the library.

2nd. To consider needs of space and furniture

Premises thought to give multipurpose services

- Halls that can give lending and magazine service, such as the service of exhibition and documental presentation halls (which can accompany the plastic arts exhibitions or the documents lent more frequently). This way we make it easier for the library to be an exhibitor and a presenter of its documental collection.
- In all areas the need of different spaces is noticed: reading, working alone, group working, silence...
- Spaces with different areas are sought: the tale area, to carry out workshops, reading group. Spaces which are easy to manage both with the library open or closed to the public.

5 Immediate consequences of including the evaluation stage in the process of creation and improvement of a library

As we developed in previous sections, the MLS has implemented the evaluation process to detect things that can be improved in any one of the stages of creation and improvement of a library⁴.

In this section we will present the most immediate consequences and proposals to act in the following aspects:

- Improving provisions for the users of library services (reading interest arrangements, young people areas, reference areas)

⁴ Because of detected aspects that need to be improved or because of the evolution of the public library model and its uses or because of the aspects related to technology, such as the implementation of a greater self-service.

- Improving conditions of the staff's working place, especially the customer service and the lending service
- Planning more sustainable buildings, both environmentally and economically

5.1.1 Improvement of the provision of library services: reader interest arrangements

Aspects to bear in mind:

- The reading interest arrangements have the following goal: to boost and give visibility and to facilitate accessibility to the collection and/or subjects, through gathering different subject matters that normally are dispersed according to CDU classification, either because of users' repeated informative demands or because of the relevance of the subject.
- Reading interest arrangements can be temporal or permanent, depending on their duration.
- Performance studies of the XBM libraries' collection make us think that we can commit to reading interest arrangements (from now on, CI), because only 32% of books were lent in 2011⁵. If the organisation of the collection responds to a specific interest of the user, the lending increases: 50.1% CI comic books, 50.5% CI language-course books, 47.3% CI of large-print books, etc.

Action proposal:

- They must be promoted according to the users' interests, both the temporal ones and the permanent ones.
- The reading interest arrangements will coexist with a more traditional organisation of the library.
- The reading interest arrangements are essential to move towards a more exhibitivite library model.
- Counting on them means having more linear square metres of shelving and furniture with an exhibitivite function.

⁵ In audiovisual collection the percentage surpasses 63%.

- Committing to reading interest arrangements is complemented with other guidelines to achieve a more exhibitive library: to promote the usage of the collection (marketing), to have a development of the collection policy (with expurgation criteria and policies), participating in collection exchange projects, to improve the display of the collection, boost the acquisition of digital formats, etc.

5.1.2 Improvement of the library services provision: Young areas

Aspects to bear in mind:

- Young people areas are not included in the standards of public libraries in our country, and few libraries have specific spaces, except some that coexist with youth information services, which are managed through another municipal department.
- Coexistence between both services, when it occurs, is more to share spaces than to create synergies between services.
- We are not providing offers to young people according to their demand (a clear example of this is music).
- According to the last XBM usage study (June 2011):
 - 17% of the users go to the library to study. From these, 23% are young people and they go to the library when they have exams.

This study also reflects that:

- 13% of the users go to the library to carry out thematic searches, and from these, 55% are young people who value, mainly, the possibility to connect to Internet.
- Other service data (2011):
 - Young people between 15 and 24 years old represent 17% of the XBM library cards.
 - 30% of Wi-Fi connections during 2011 are related to these ages.
 - 17.75% of lending uses correspond to young people, which represent 16.5% of the lending users.

Action proposal:

- Better planning of spaces and library services for young people according to each local reality.
- We commit to the coexistence between both services sharing a space, as a first step to create synergies between services.
- Need to identify the library collection in a space with more informal furniture (lower furniture for searches, informal seats, armchairs...)
- In libraries where there is a young area, it is necessary to plan soundproofing from the rest of the library and organise spaces so that they allow for an interrelation of these spaces with the rest of the library. In our society, public libraries have a very important role in intergenerational meeting.
- An accurate offer for the young people of online library services makes it necessary to provide a Wi-Fi connection in the young people area (lots of sockets). This need is more important than providing a lot of computers for the area. We value positively the introduction of strategy games, also in a technological format, such as Wii and Play-Station.
- Aside from equipping the area, we guide the library directors to the need of cooperating with other municipal services to design specific services for young people. Some examples are the "technology couples" projects, in which young people teach old people all about technology.

5.1.3 Improvement of the provision of library services: reference areas

Aspects to bear in mind:

- The changing use of reference works
- The change from printed versions to new formats on the editorial market.

Action proposal:

Before that context, some changes have been introduced in the reference areas planned for new libraries, fitting this space to uses and needs of present services. At present we have some specific actuation guidelines which differentiate the actions we have to follow depending on the type of library and the characteristics of the population to serve. The specific titles that constitute the collection and the equipment are also determined by these guidelines.

Moreover a warning service has been created to remove the materials that are obsolete.

Until not long ago, reference areas played a main role in the space distribution and they were placed in very visible places, aside from the rest of the documental collection. At present, these areas have been substituted by novelty displays and reading interest arrangements, following models both organisational and of presentation of the collection which are much more attractive to the users.

Today, in libraries in small towns and in libraries next to urban networks, reference areas have disappeared as single spaces and their collection has been integrated into the rest of the collection. On the other hand it has been considered convenient to continue keeping a separate space in large libraries.

5.2 Customer service and lending service desks

Aspects to bear in mind:

- Changing the library model, in which the librarian becomes a reading prescriber⁶
- Introduction of technology (radio frequency, self-lending service...)
- In our Mediterranean society human relations are very important, and we must continue to promote a quality customer service. In the last survey of user satisfaction (2011), the items most valued were cleaning (8.5) and personal relations (8.4).

According to the same survey, when searching for a book, 28.9% of those polled ask the library staff for it (in the survey carried out in 2007, the number was 22.5%).

Action proposal:

- A change in the customer service and the lending service management requires a change in the desk orientation. The desk is a key element in this service. We want to vouch for desks as places to reinforce this customer service, not so much as workspaces.

⁶ In the XBM project of the Biblioteca Virtual (virtual library) <http://bibliotecavirtual.diba.cat/>, one of the most highlighted sections is the reading recommendations section, taken care of by library professionals and library users. See also project Bibarnabloc: <http://bibarnabloc.cat/>

Good resolution of our lending desks, as far as conception and location are concerned, is an important challenge for the two sections of the GBS involved in the creation and improvement of the libraries.

5.3 Planning buildings bearing in mind the maintenance cost

Aspects to bear in mind:

- Maintenance costs in libraries represent for the City Councils in average 62.07 euros/m² of surface per year (2011). These expenses include concepts of consumption (water, electricity, gas...), cleaning, maintenance investments and insurance. These expenses have increased slightly in the past few years, basically because of the rise of supply costs in our country. Maintenance expenses represent, for City Councils, an average of 28% of their expense in maintenance for library service.
- Maintenance expense is one of the highest costs of the City Councils' economic contribution, together with the cost of human resources.

Action proposal:

- We have to plan sustainable buildings right from their conception (especially on programming and architectural project stages). The programming stage must bear in mind those interventions that are really necessary and according to regional instruments of planning. The MLS has strongly vouched for public library standards and for a balanced development of the service.
- The architectural project stage has to foresee premises not too expensive to maintain (it is important to have a good library organisation, to use materials which are inexpensive to maintain, etc).

6 Conclusions

- The evaluation process that we have implemented is very appropriate, mainly if we bear in mind the economic environment in our country and the financial weaknesses of administrations. Also because of the need of constant revision of the public library and the services improvement.
- Evaluation has provided us improvement in each project, and mainly the possibility to put the improvements into practice in

further projects. This becomes very relevant in a networking model like ours, in which we vouch for shared learning.

- The fact that we have differentiated stages and different goals in each stage has helped us understand more globally the project. It improves the belonging feeling.
- The evaluation process that we have shown is complemented by the continuous evaluation of the service, which is promoted from our Institution, conscious of the responsibility we assume with the citizens, when offering a quality public service⁷.
- We identify as new challenges the following aspects: spaces that have to be improved, more technological deployment, libraries with more self-service, more prescriber personal. We want to pay attention to the evolution of virtual services that, as networked libraries we provide through Biblioteca Virtual (virtual library) <bibliotecavirtual.cat>, and see how this virtual offer influences on the service offer in libraries.
- All in all, results of the XBM libraries as a whole help us to continue. In our country, public libraries still are the public premises more used by citizens. Visits to libraries have increased and they have reached the 17,770,928 visitors. We highlight a notable rise of virtual access to libraries, with 8.8 million visits. We can say that the increase of virtual use of the public library has come together with an increase of use in person, consolidating the library areas as a meeting and exchange spaces, which favour social cohesion.

7 Annexes

-Questionnaires

-Relation of libraries where the evaluation was carried out with the appropriate information

⁷ See “avaluació de serveis i estadístiques (“evaluation of services and statistics”)
<http://www.diba.cat/biblioteques/treballenxarxa/quefem/xarxabiblioteques/avaluacioserveis.asp>

Biographical information of authors:

Mercè Millán:

Librarian, Documentalist and Contemporary History Graduate.

Currently working as Head of Buildings Programs and Equipment Section (since October 2009) at Library Services Management - Diputació de Barcelona (Barcelona Provincial Council).

Prior to this, between 1996 and 2009 she worked as Mataró City Public Library Director and as Maresme County Coordinator of 23 public libraries.

She has published several articles on public library management and reading promotion.

Ester Omella:

Library and Political Science and Sociology Graduate.

Currently working as a Head of Planning, Evaluation and Quality Section (since 2005) at Library Services Management - Diputació de Barcelona (Barcelona Provincial Council).

Prior to this she worked in public library, in national and international bodies such as IFLA (she was responsible of IFLA Congress in Barcelona 93), and as a teacher of Universitat de Barcelona.

She has published several publications in the field planning and evaluation of public libraries.

Assun Viladrich:

Degree in Librarianship and Documentation and Planning and Management Graduate Library.

She is currently responsible for the New Equipments Unit (since 1998) at Library Services Management - Diputació de Barcelona (Barcelona Provincial Council).

Prior to this she worked there as a Program Director for New Libraries Equipment (1992-1997) and as a librarian in Santa Coloma de Gramenet public library (1985-1991).

She has published articles about public libraries.